

Product Identification

- **Purpose:** The document is intended for use by end-of-life recyclers or treatment facilities. It provides the basic instructions for the disassembly of FI32U products to remove components and materials requiring selective treatment.

Marketing Name/Model	Description
Gigabyte AORUS FI32U	LCM 32"

Tools Required

- List the type and size of the tools that would typically be used to disassemble the FI32U to a point where components and materials requiring selective treatment can be removed.

Tools Description	Toole size(if applicable)
Screwdriver	PH2
Disassembly tool	N/A

Product Disassembly Process

- **List the basic steps that should typically be followed to remove components and materials requiring selective treatment:**
- **Depending upon the complexity of the disassembly process, a graphic depicting the locations of items contained within the product which require selective treatment (with descriptions and arrows identifying locations) can be inserted below:**

Disassembly steps 1 - Disassemble the front and rear covers

Step 1-1. Unscrew the screw of the rear cover.



Step 1-2. Separation the rear cover on back side and pull around out hook by disassembly tool.



Disassembly steps 2 - Separate the front and rear covers

Step 2. You need to unplug the cables plugged into the main board connector before you can separate the front and rear covers.

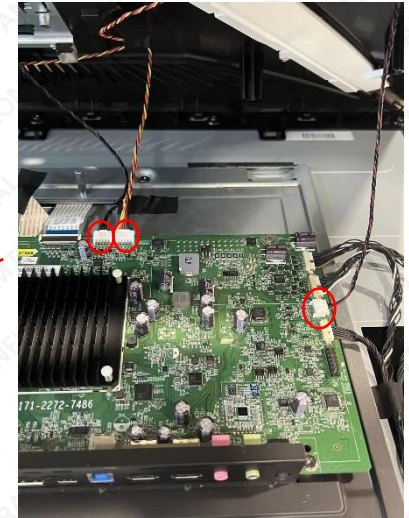
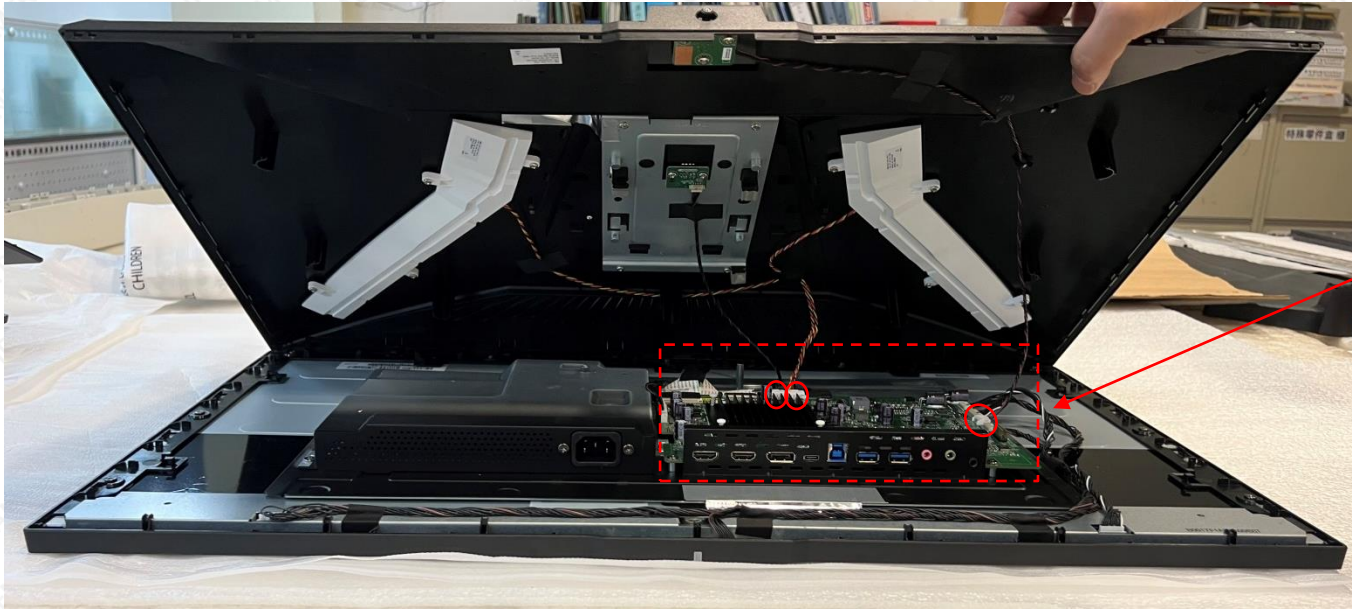

Disassembled into two parts

1.Rear cover (page8~13)



2.Front cover (page14~23)

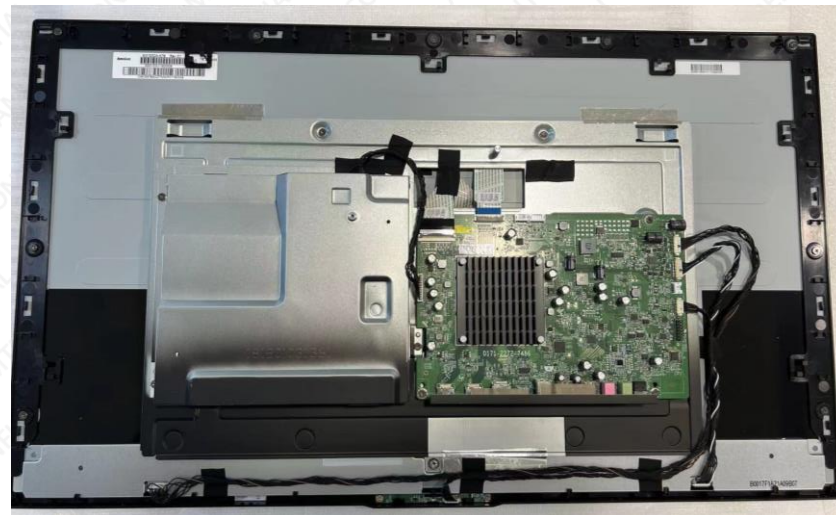

▼ The following disassembly steps are divided into two parts (rear cover first) ▼

Rear cover disassembly steps 3 - Separate the PCBA in the rear cover

Step 3-1. Remove the 3 black tapes.

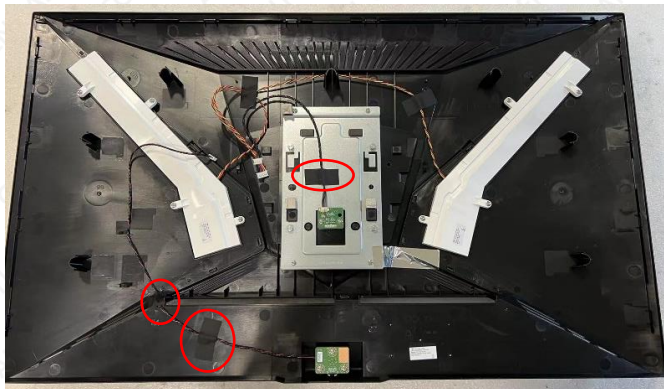

Step 3-2. Unscrew the 5 screws of the 2 PCBA.

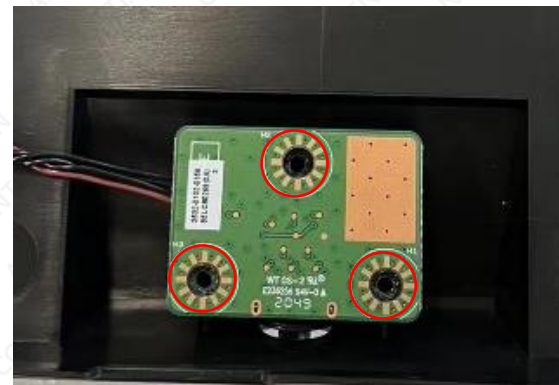
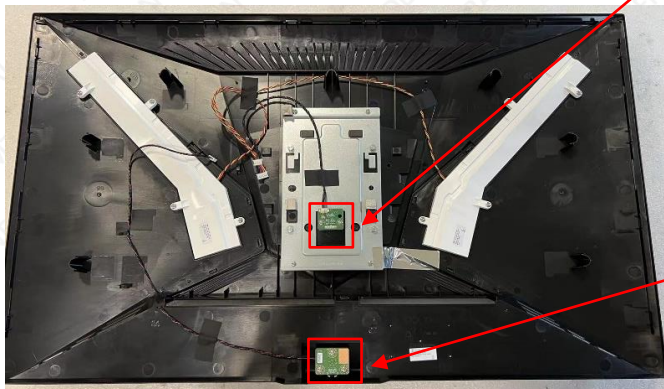

Rear cover disassembly steps 3 - Separate the button cap on the button PCBA

Step 3-3. Remove button cap on the button PCBA .

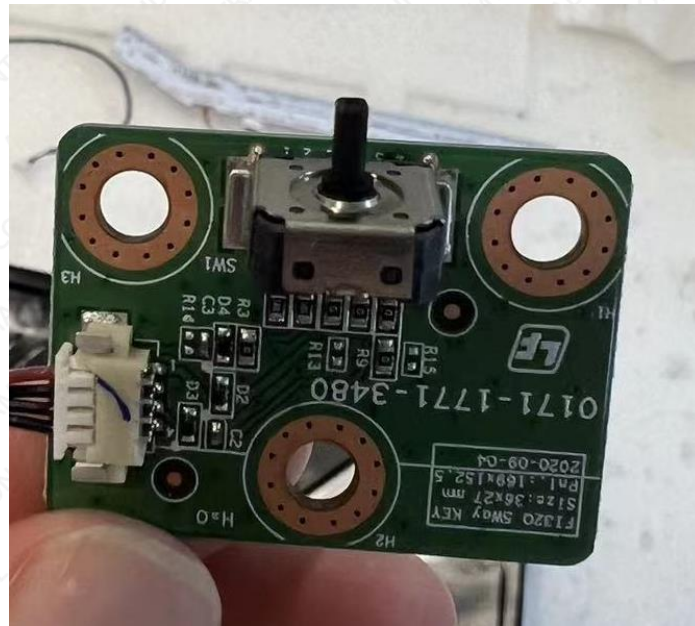
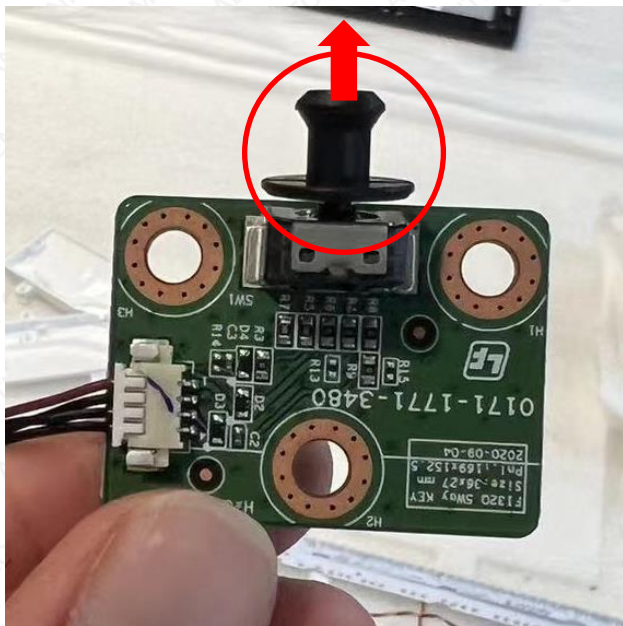

Rear cover disassembly steps 4 - Separate the LED covers in the rear cover

Step 4-1. Remove the 2 black tapes.

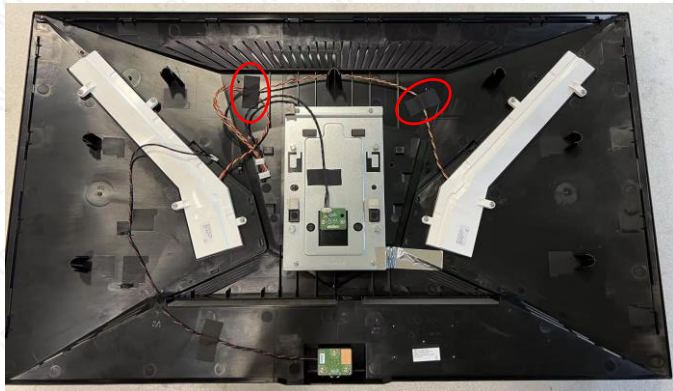

Step 4-2. Unscrew the 8 screws of the 2 LED covers.

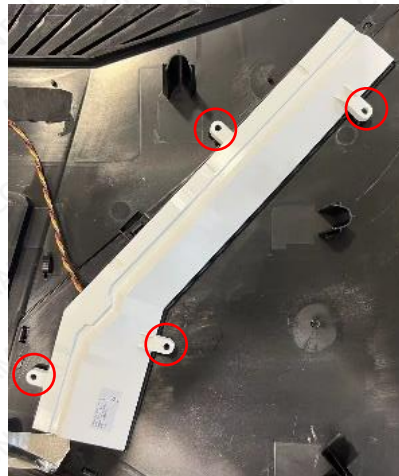
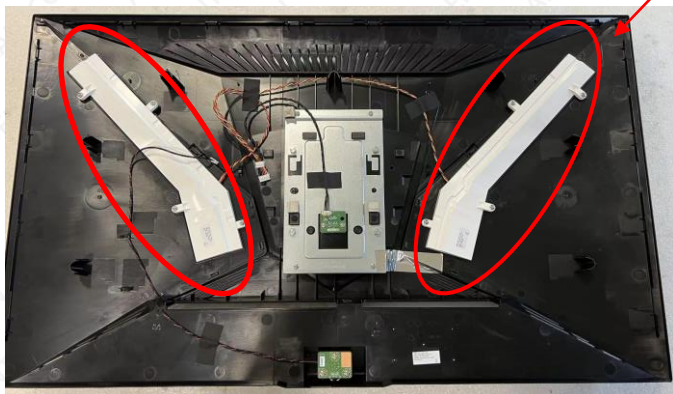

Rear cover disassembly steps 4 - Separate the LED PCBA in the LED cover

Step 4-3. Remove the LED PCBA in the LED cover and unplug the 2 cables in the connector.

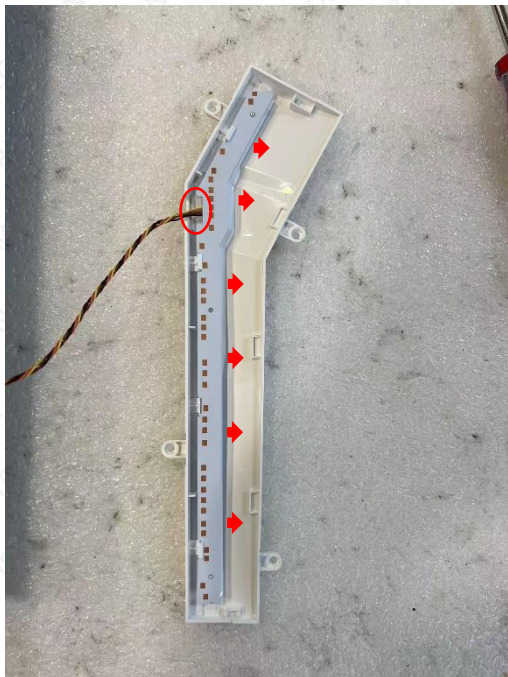

Rear cover disassembly steps 5 - Separate the wall mount BKT in the rear cover

Step 5. Unscrew the 4 screws of the wall mount BKT and remove the AL tape .

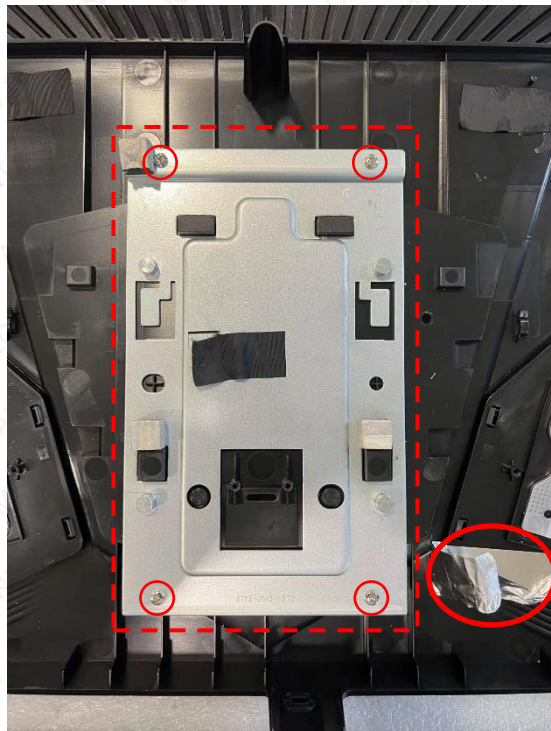

AL tape

Rear cover complete

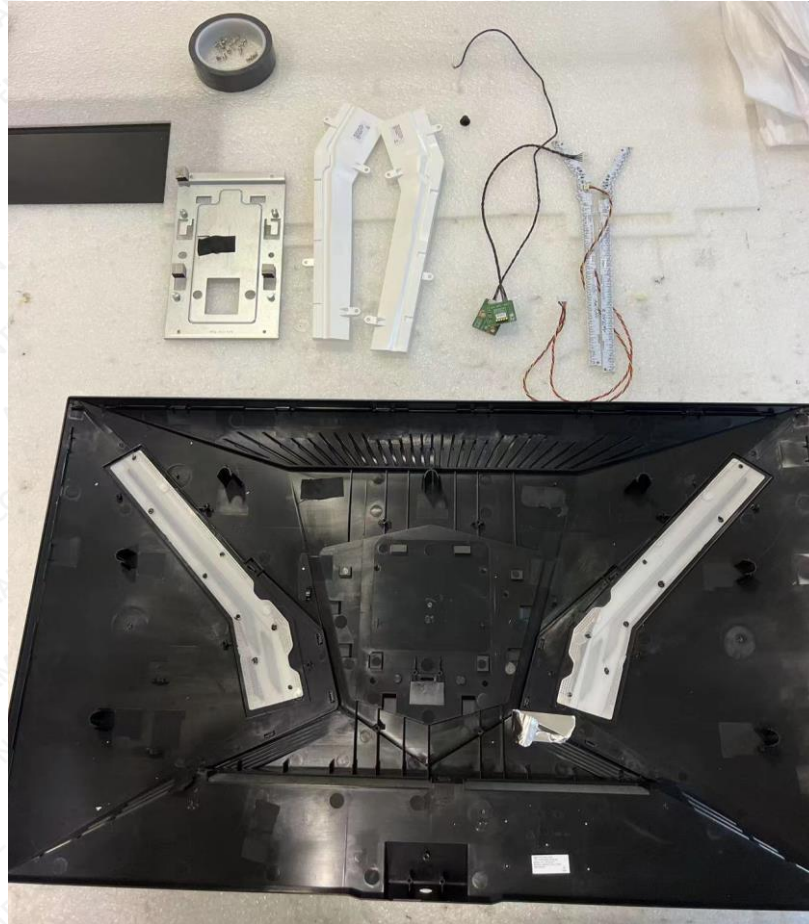

Front cover disassembly steps 6 - Separate the cables connected to the main board

Step 6-1. Unplug the 3 cables and 2 FFC of the connectors on the main board.

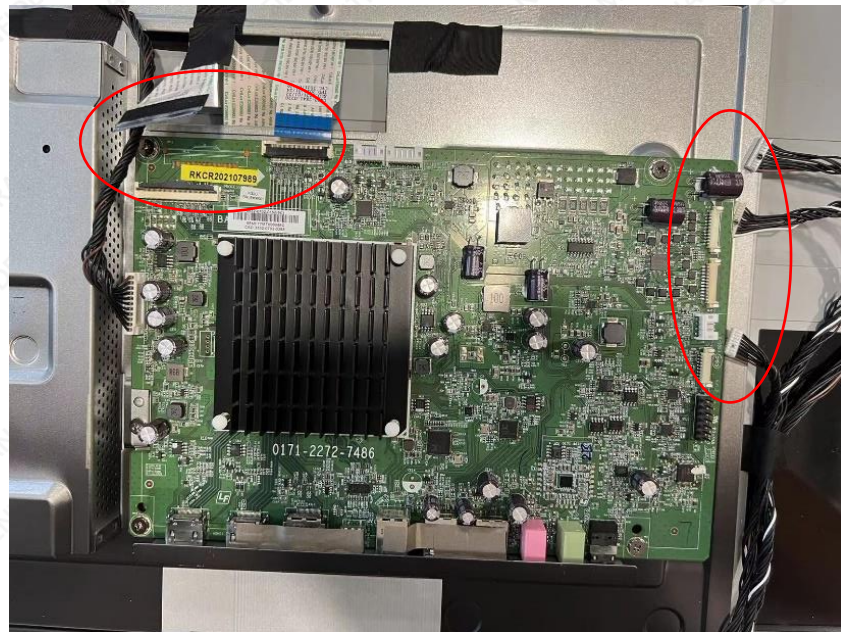
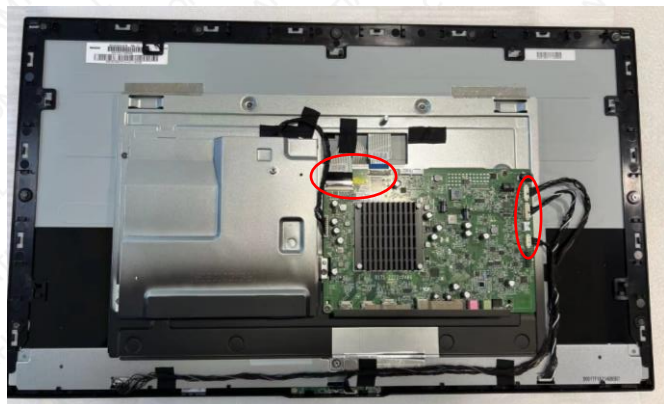

Step 6-2. Remove the 3 silver tapes between the panel module and the tray.

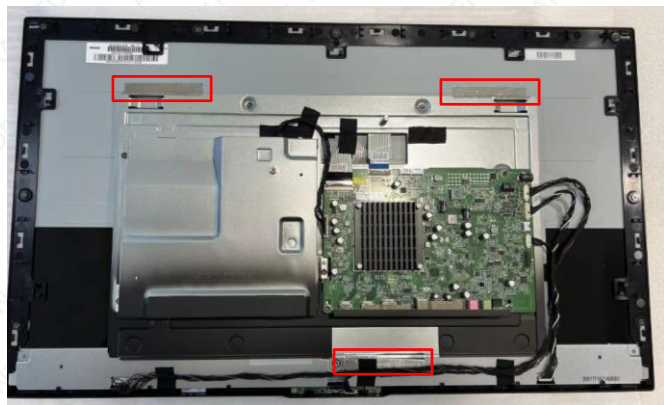

Front cover disassembly steps 7 – Remove the cables and tapes in the front cover

Step 7-1. Remove the 5 black tapes.

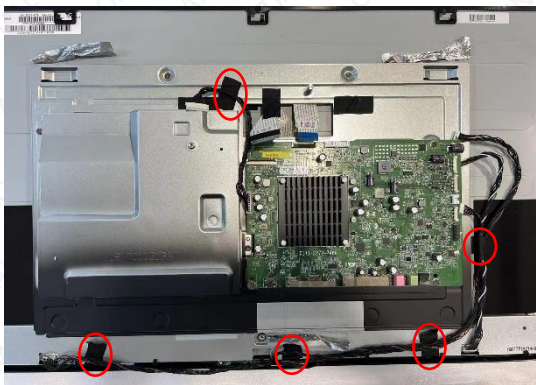

Step 7-2. Unplug the 4 cables of the connectors on the panel module and the power board.

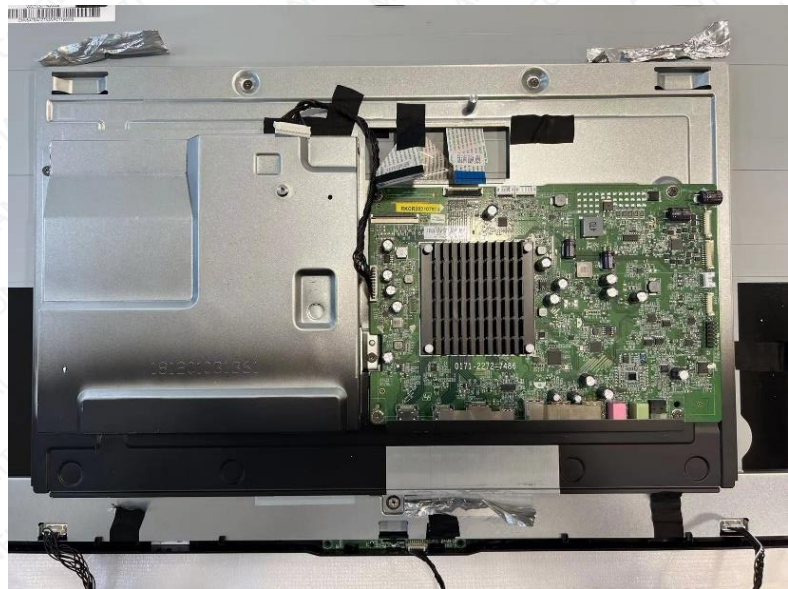
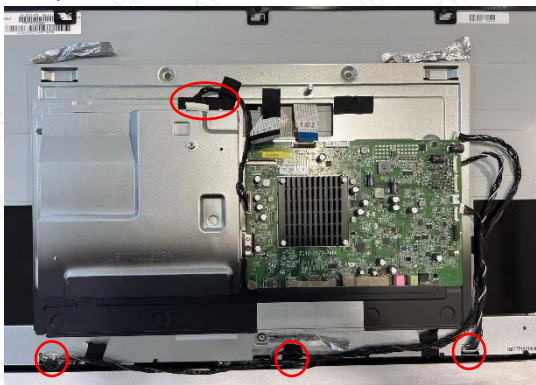

Front cover disassembly steps 8 – Separate the PCBA on the ground side of the front cover

Step 8. Unscrew the 2 screws on the PCBA on the ground side.

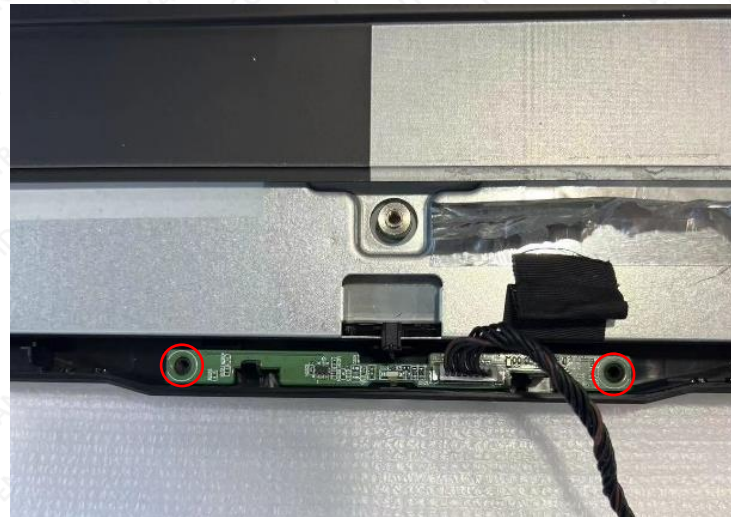
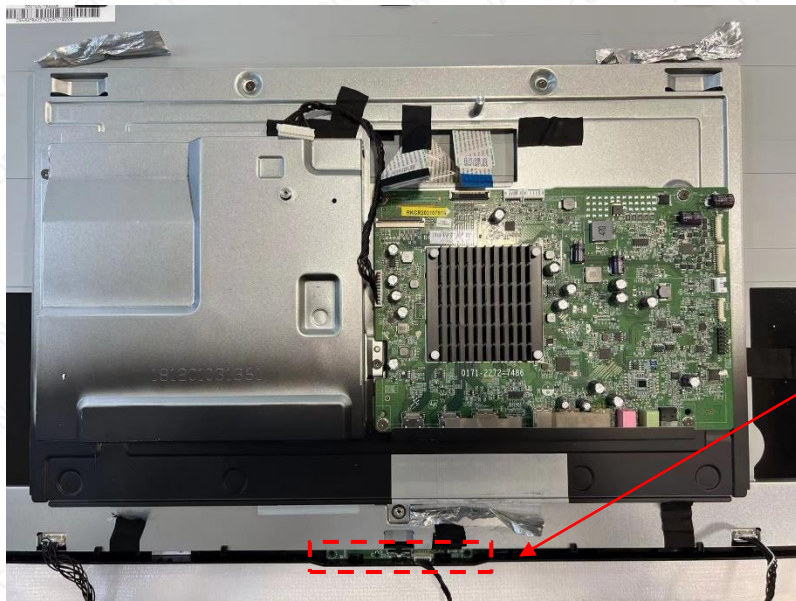

Front cover disassembly steps 9 – Separate the shielding in the front cover

Step 9. Unscrew the 5 screws of the shielding.

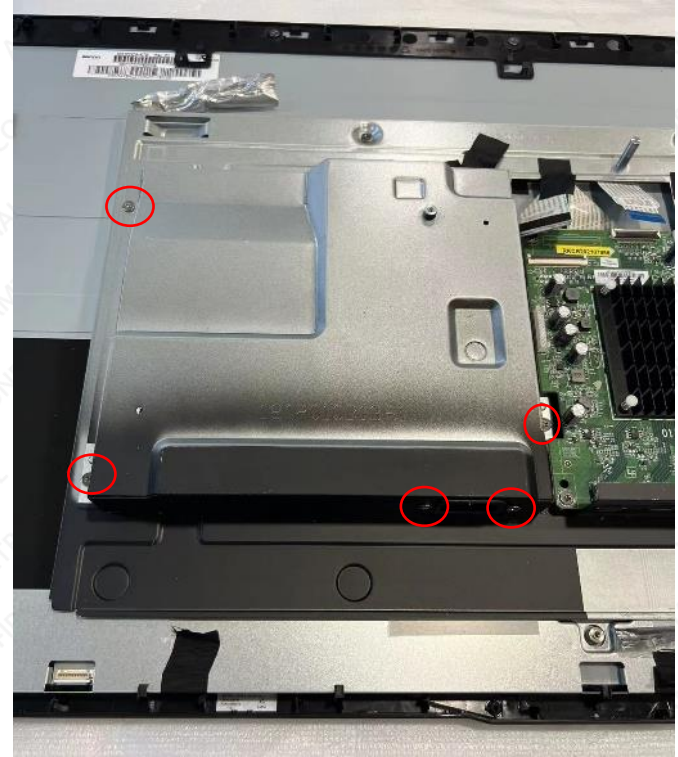
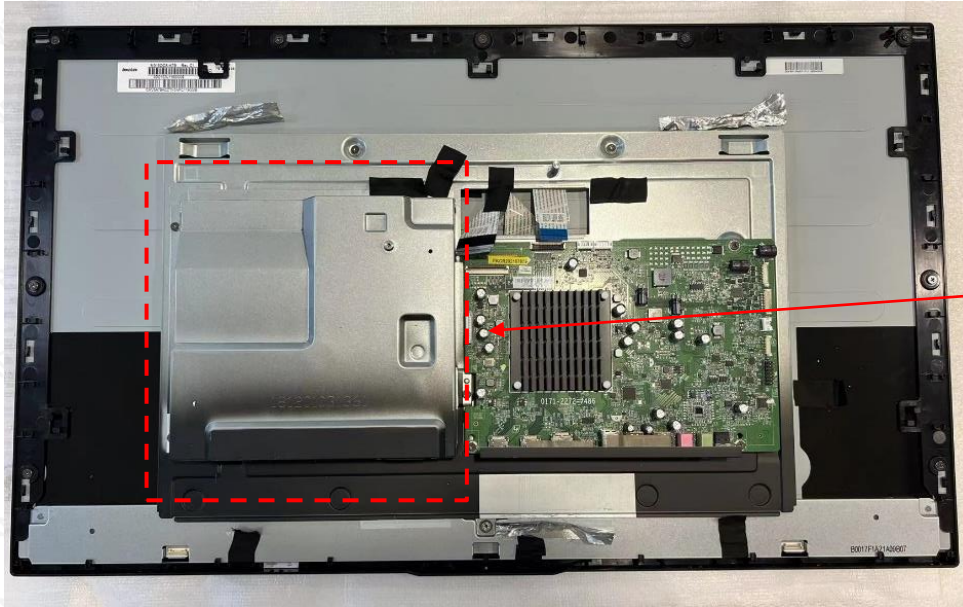

Front cover disassembly steps 10 – Separate the power board in the front cover

Step 10. Unscrew the 5 screws of the power board.

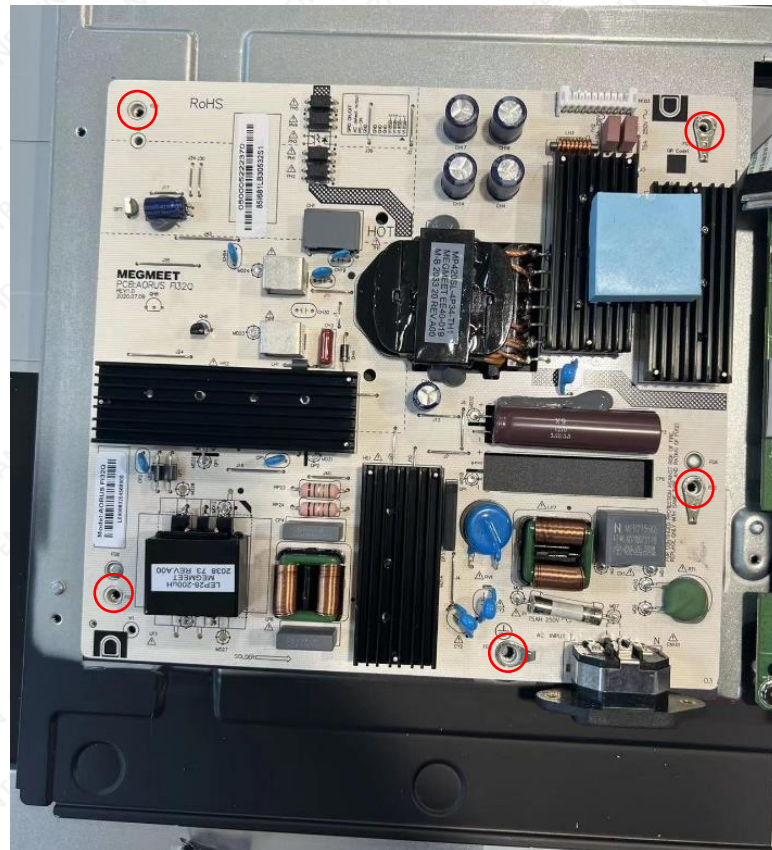
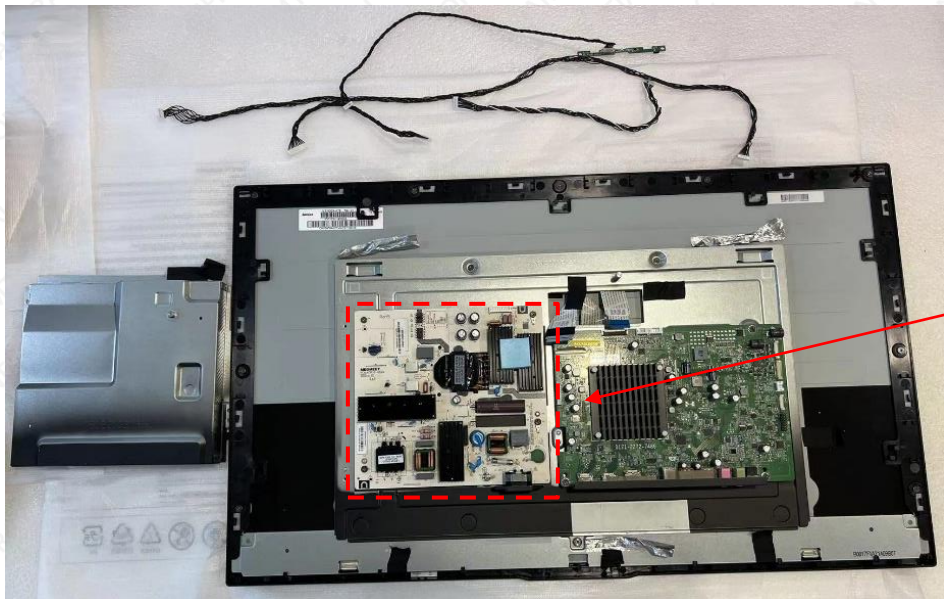

Front cover disassembly steps 11 – Separate the main board in the front cover

Step 11. Unscrew the 4 screws of the main board.

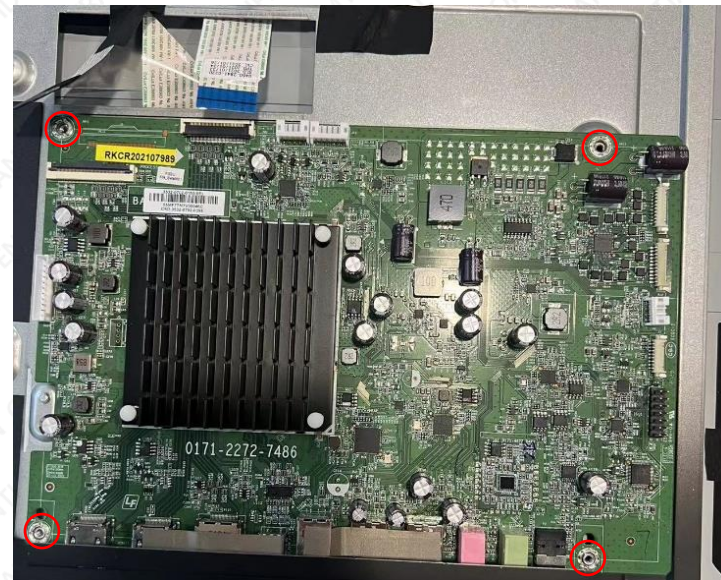
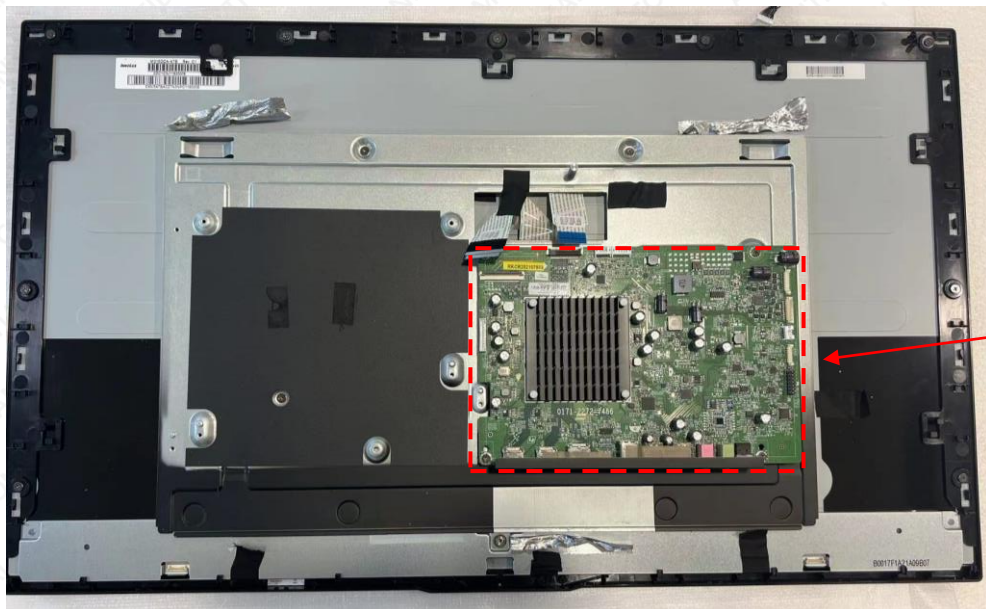

Front cover disassembly steps 12 – Separate the tray in the front cover

Step 12. Unscrew the 4 screws of the tray.

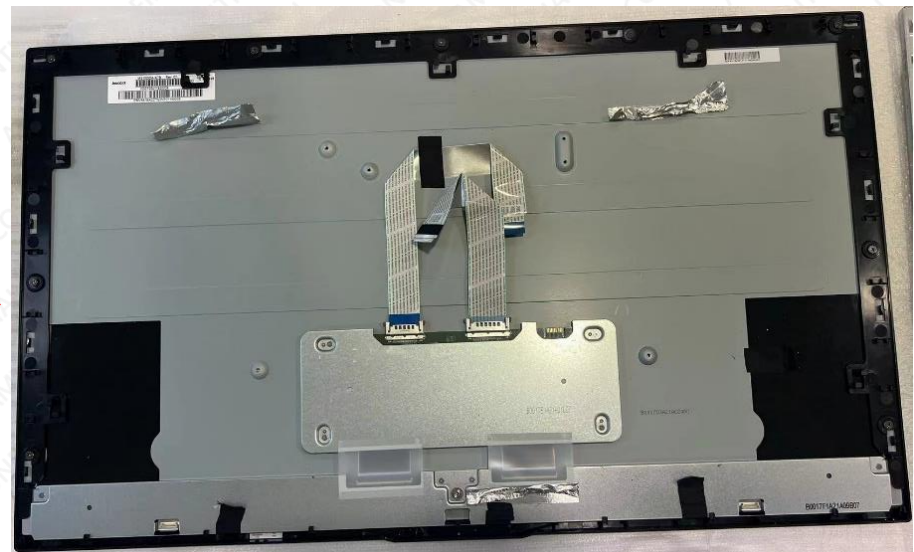
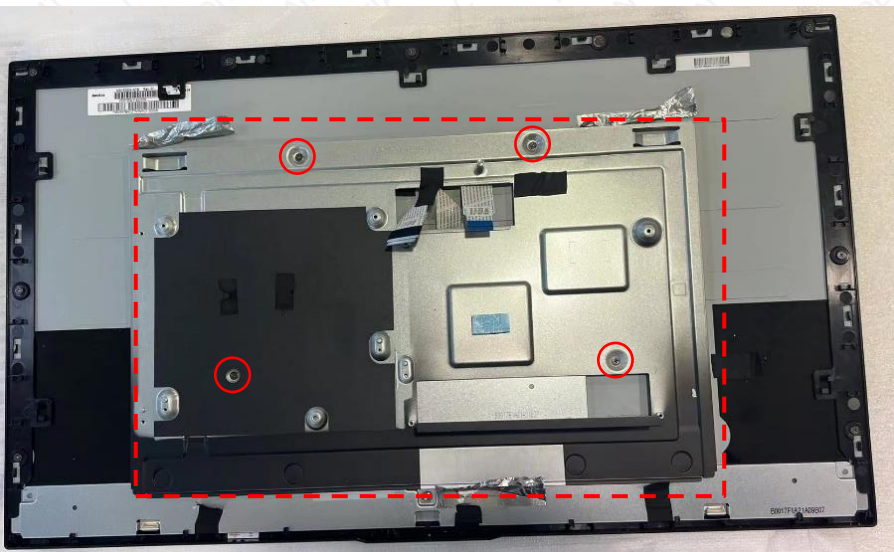

Front cover disassembly steps 13 – Separate the FFC in the front cover

Step 13. Remove the black tape.

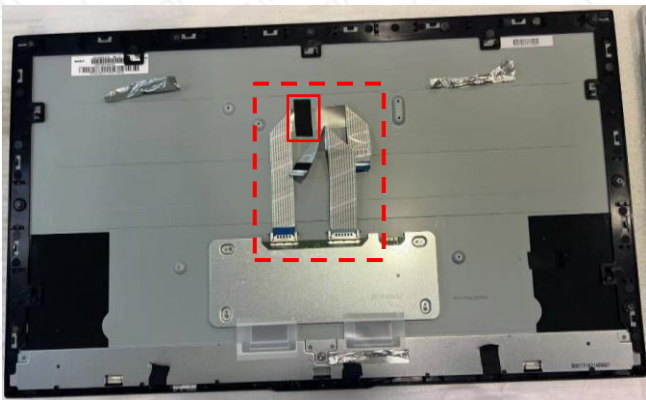

Step 13. Unplug the 2 FFC of the connectors on the panel module.

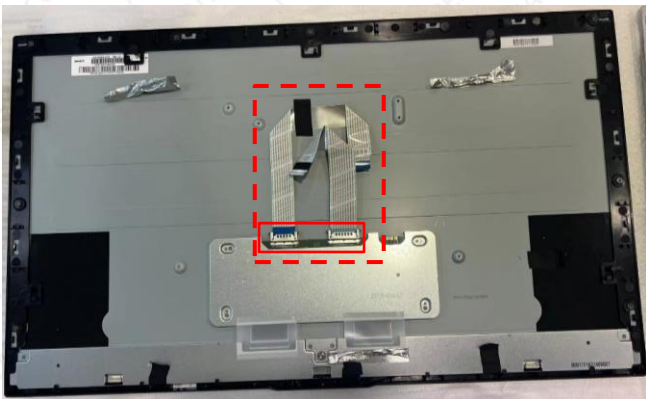

Front cover disassembly steps 14 – Separate the front bezel

Step 14-1. Unscrew the 9 screws of the front bezel.

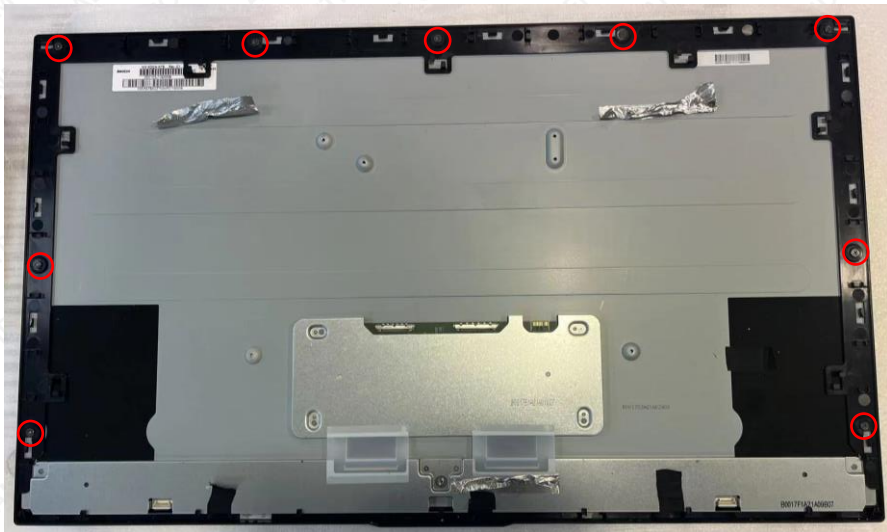

Step 14-2. Disassemble according to the direction and order shown in the photo below.

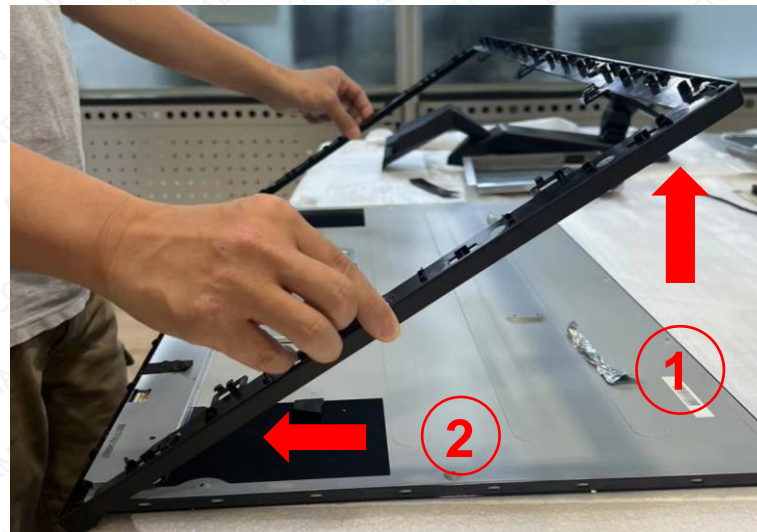

Front cover complete



Exploded view diagram with list of items

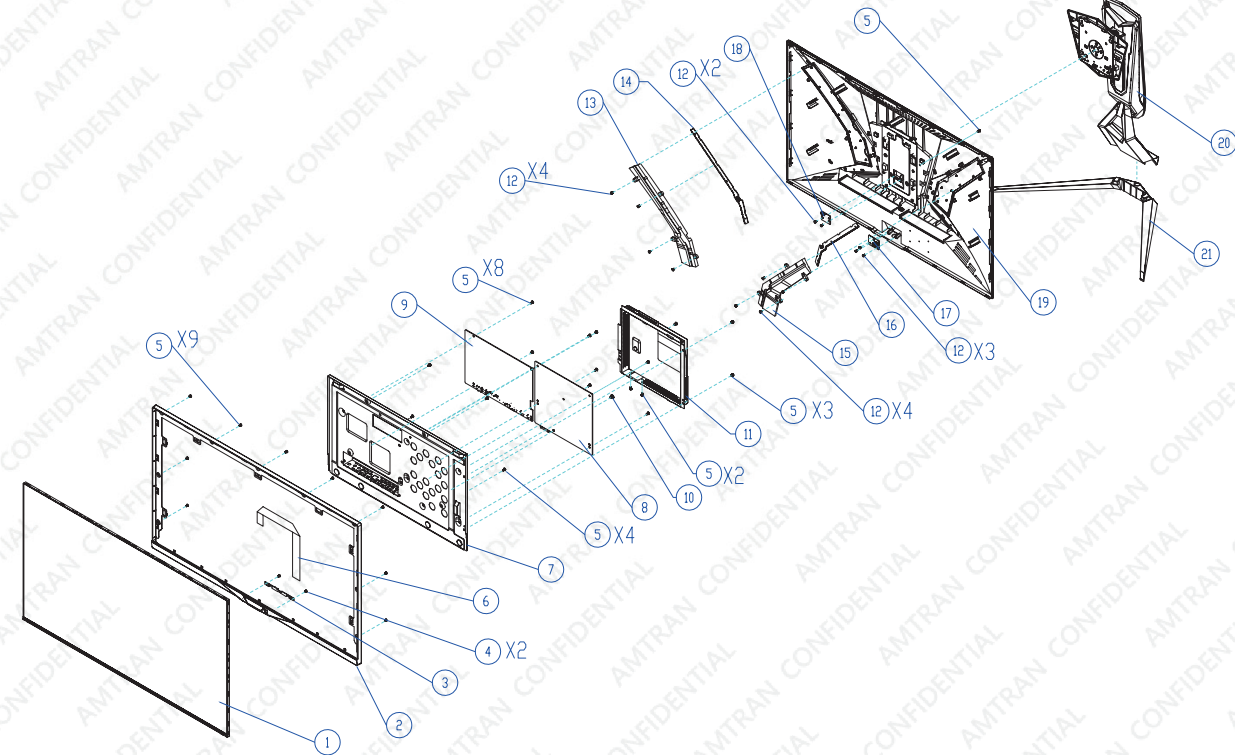

Item	Description	QTY
1	LCD MODULE 32" 144Hz UHD TFT M315DCA-K7B (INX_Ningbo)	1
2	FRONT BEZEL (ABS 94-HB/T52013) (FI32U) ASSY	1
3	AUDIO (Microphone) BD ASSY GIGABYTE AORUS FI32Q	1
4	TAP. SCREW-TI #3.0*4.0L, Ni	2
5	MAC. SCREW-MI M3.0*4.0L, BLK-NI (HEAD=7.0)	27
6	FFC 51P 199mm(2 FOLD) G/F AC+A10 W29.55+AL(BA)	1
7	M/B TRAY BKT(SECC 0.6t) (FI32Q) ASS'Y	1
8	PSU ASS'Y R00101343 for GIGABYTE FI32Q/FI32U	1
9	M/B ASSY GIGABYTE AORUS FI32U_INX_M315DCA-K7B_RT D2718QD-CQ (PCB 235x160) (HDCP)	1
10	MAC. SCREW-MPGW M4.0*8.0L, Ni	1
11	POWER BD SHIELDING (SECC 0.81t) (FI32Q) ASS'Y	1
12	TAP. SCREW-TB #3.0*6.0L, Ni	13
13	LIGHT COVER_L (ABS 94-HB/WHITE) (FI32Q)	1
14	LED BD ASSY GIGABYTE AORUS FI32Q for L WING (PARA LIGHT)	1
15	LIGHT COVER_R (ABS 94-HB/WHITE) (FI32Q)	1
16	LED BD ASSY GIGABYTE AORUS FI32Q for R WING (PARA LIGHT)	1
17	DISPALY BD ASSY GIGABYTE AORUS FI32Q	1
18	CONNECTOR BD ASSY GIGABYTE FI32Q	1
19	REAR COVER (ABS 94-HB/T52013) (FI32U) ASS'Y	1
20	HINGE ASS'Y (FI32Q)	1
21	BASE (AL DIE CASTING/BLACK) (FI32Q)	1