

AORUS WATERFORCE Water Block graphics card INSTALLATION GUIDE

Installation

Step 1

- ① Install the graphics card into the system. When positioning it in the loop, please take notice that water blocks must receive the coldest coolant as possible.
- ② Carefully determine the optimal tube routing and install the compatible fittings and optionally the plugs.

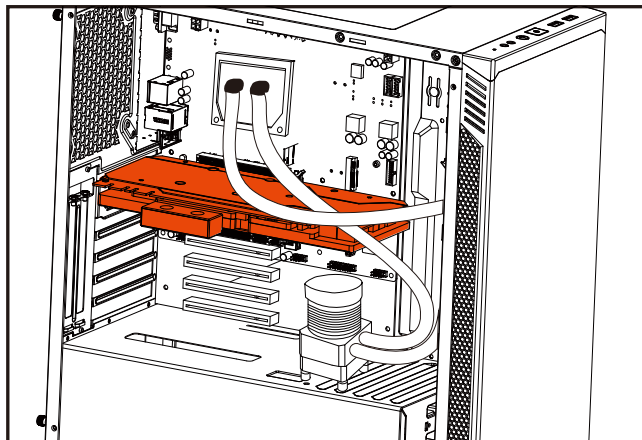

Step 2

- ① Measure the length of the tube that is needed to connect the GPU water block to your system, such as the GPU water block to the pump-reservoir unit and CPU to GPU water block. Make the correct tube length you need.
- ② Attach the tube onto the both fitting barbs until it sits firmly. Secure the fitting compression ring to make the assembly complete. Check again that all of the tubing is secured by compression fittings as intended.
- ③ Please make sure that the tube is not bent or twisted. This way the coolant will be able to flow without restriction.

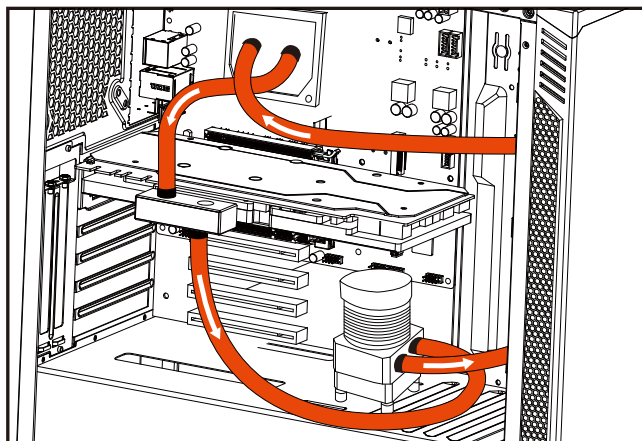

It is best practice to run your pump for at least 24 hours in order to ensure the system is leak free. Once the 24 hour leak test has been completed and there is no sign of leaking fluid you are free to finish your computer build.



It is recommended to protect the exposed hardware with a few paper towels in order you have a leak or mistakenly spill the coolant when pouring it.

Safety cautions

- ① If you spot any leaks, turn off the power immediately.
- ② Never run water cooling system on tap water and always use the cooling concentrate in correct ratio with distilled water.
- ③ Never use alcohol, alcohol derivatives or alcohol based solvents in the system. Using alcohol might result in permanent damage to liquid cooling KIT components, especially acrylic parts of the system.
- ④ Never let your pump run dry. If this is happening for a prolonged period of time you may risk destroying each component in the system.
- ⑤ Keep and store the product away from the reach of children.
- ⑥ All components are subject to damage if the product is incorrectly installed.
- ⑦ Check the component list and condition of the product before installation. If there is any problem, contact the shop where you have purchased the problem to get a replacement or refund.
- ⑧ GIGABYTE is not responsible for any damages due to external or personal causes, including but not limited to, improper use, problems with electrical power, accident, neglect, alteration, repair, improper installation and improper testing.